

GENERAL NOTES :

CONVEYOR WEIGHT : 298 LB (without garment)
 APPROX. STORAGE CAPACITY : 204 GARMENTS

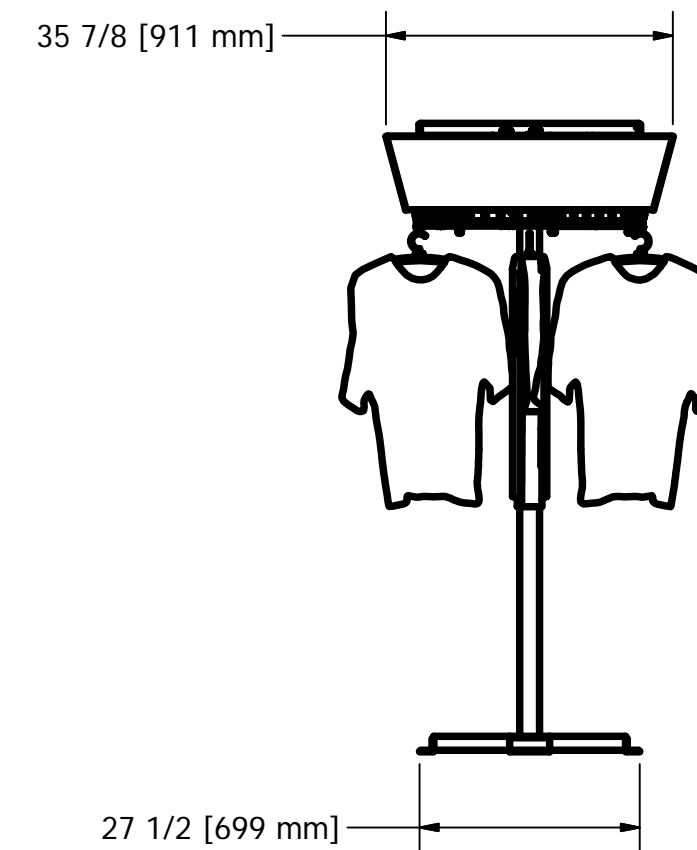
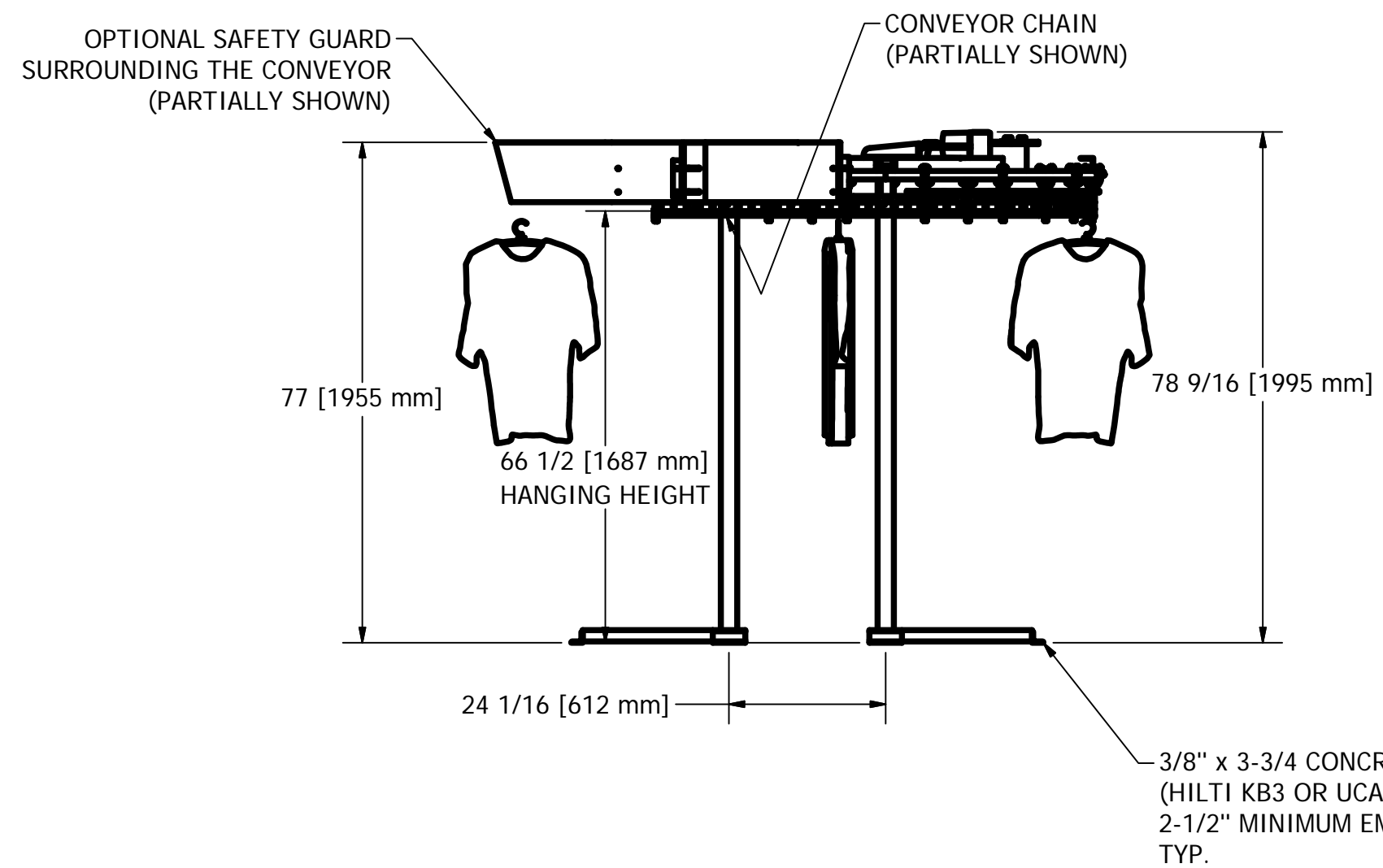
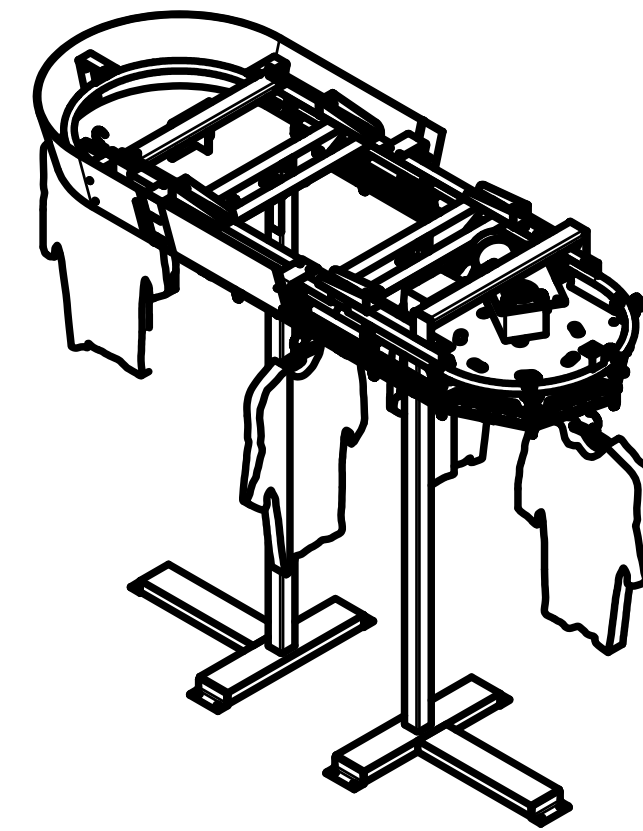
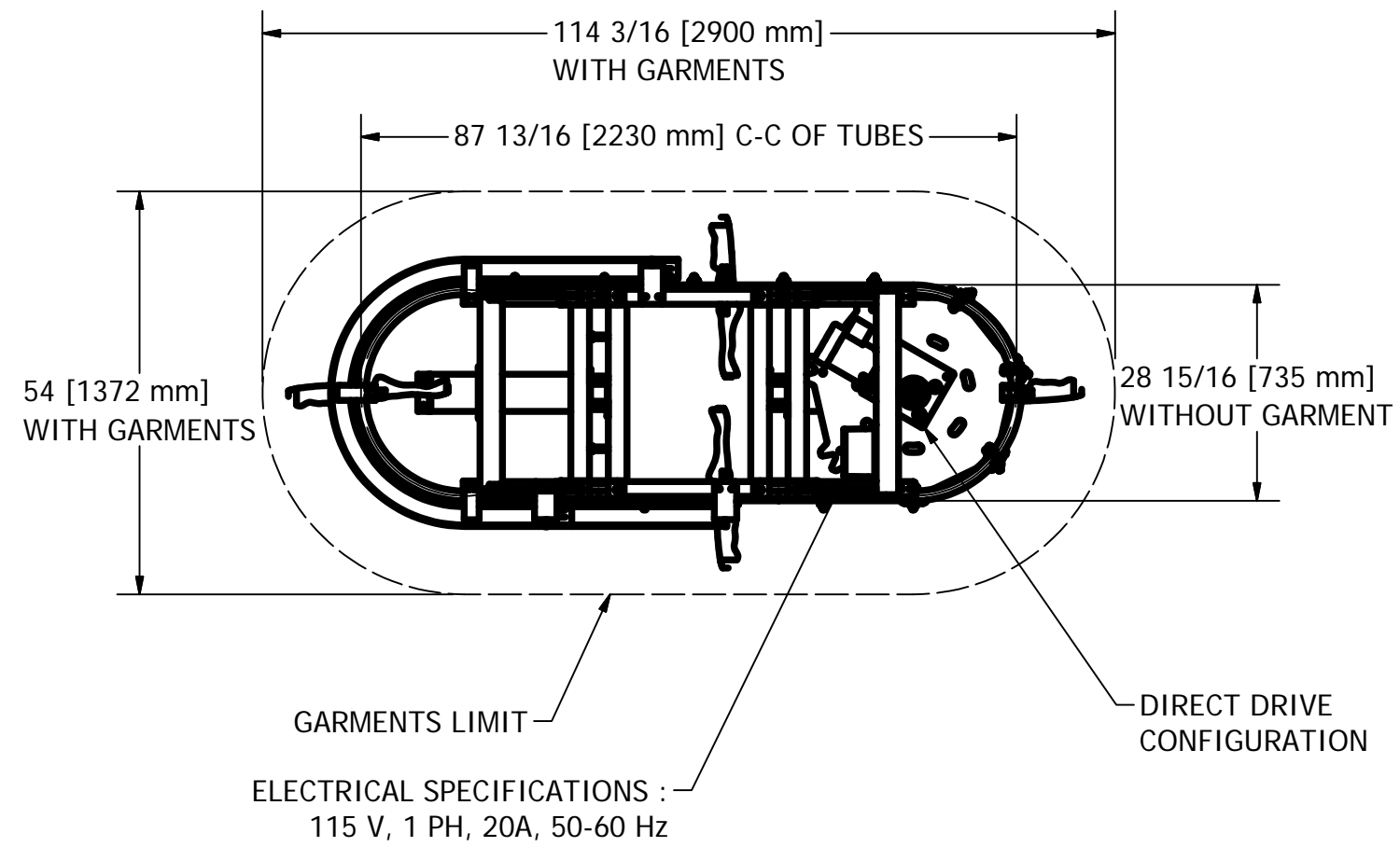

DESIGN F. ROULEAU	DATE 8/21/2008	 www.planiform.com
DRAWN F. ROULEAU	DATE 1/12/2010	
CHECKED	DATE	
GENERAL TOLERANCES .X +/- .030 .XX +/- .010 .XXX +/- .005 FRACTION +/- 1/16		TITLE GARMENT CONVEYOR SIZE DWG NO C NPF-170 SCALE 1/2" = 1'-0"
		REV